

(2) 1/2" x 1 3/4" HEX HEAD, STAINLESS STEEL BOLTS AND WASHERS AT 180° COUNTERSUNK. BOLTS & WASHERS TO BE TYPE 316 STAINLESS STEEL.

(2) OPEN PICKHOLES
1" DIAMETER

FILLETS @ R 1/8"

1/4" RAISED LETTERING
(RECESSED FLUSH)

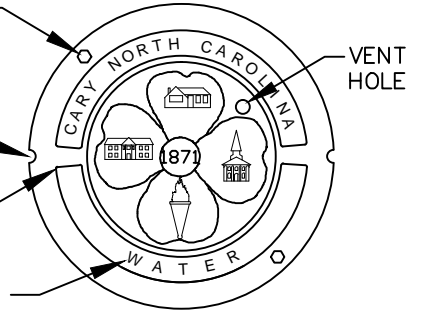

COVER TOP VIEW

RING & COVER SPECIFICATIONS:

1. CLASS 35 GREY IRON.
2. COMPLIES WITH ASTM A48 CL35B.
3. CASTING TO BE COATED WITH A WATER BASED ASPHALT PAINT (BLACK).
4. ALL LETTERING SHALL BE CLEAN, CRISP, AND CLEARLY LEGIBLE.
5. DOMESTICALLY MADE & MANUFACTURED IN THE USA.

MINIMUM WEIGHTS	
RING	180
COVER	120
TOTAL	300

NOTES:

1. TAP SIZE AND ISOLATION VALVE TO BE SAME SIZE AS AIR VALVE.
2. ALL PIPING AND FITTINGS, IN THE MANHOLE, SHALL BE 'NO LEAD' BRASS OR BRONZE UNLESS NOTED.
3. MANHOLE STEPS SHALL BE PLACED 16" O.C. AS SHOWN BY DETAIL 07000.02.
4. CONCENTRIC CONES MAY BE USED FOR AIR VALVE MANHOLES LESS THAN 5' IN DEPTH.

FOUR ANCHOR BOLTS

1/2" MINIMUM

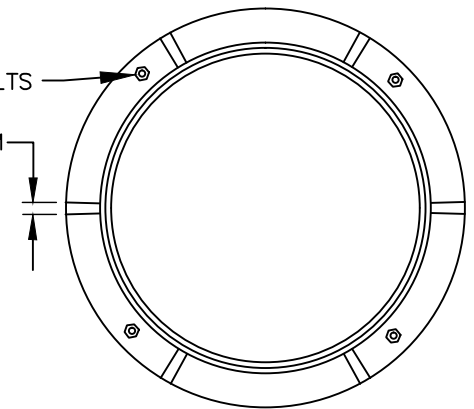

RING TOP VIEW

**STANDARD COMBINATION AIR VALVE
(FOR POTABLE WATER SYSTEMS)**

DETAIL No.

06000.15

SHEET 1 OF 2

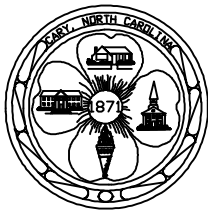

EFFECTIVE: 07/01/13