

(2) $\frac{1}{2}$ " x $1\frac{3}{4}$ " HEX HEAD, STAINLESS STEEL BOLTS AND WASHERS AT 180° COUNTERSUNK. BOLTS & WASHERS TO BE TYPE 316 STAINLESS STEEL.

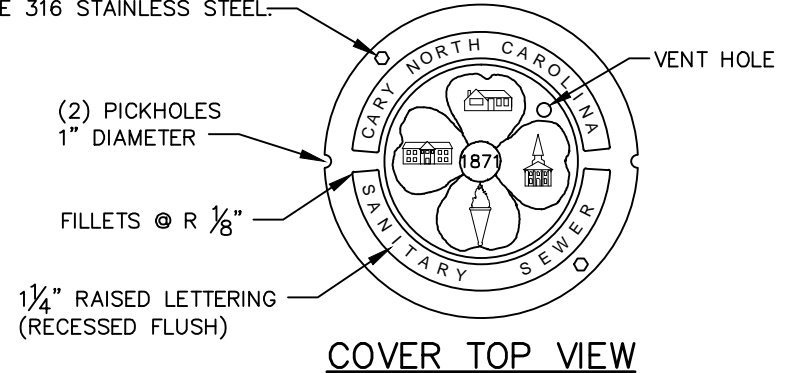

RING & COVER SPECIFICATIONS:

1. CLASS 35 GREY IRON.
2. COMPLIES WITH ASTM A48 CL35B.
3. ALL LETTERING SHALL BE CLEAN, CRISP, AND CLEARLY LEGIBLE.
4. DOMESTICALLY MADE AND MANUFACTURED IN THE USA.

MINIMUM WEIGHTS	
RING	180
COVER	120
TOTAL	300

FOUR ANCHOR BOLTS

$\frac{1}{2}$ " MINIMUM

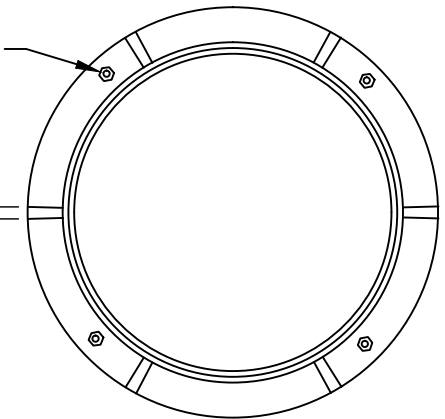

RING TOP VIEW

NOTES:

- 1) TEE FITTING AND ISOLATION VALVE TO BE SAME SIZE AS AIR VALVE.
- 2) ALL PIPING AND FITTINGS, IN THE MANHOLE, SHALL BE PROTECTO 401 LINED OR FBE COATED.
- 3) MANHOLE INTERIOR SHALL BE COATED WITH 100-mils OF AN APPROVED EPOXY COATING.
- 4) MANHOLE STEPS SHALL BE PLACED 16" ON CENTER AS SHOWN BY DETAIL 07200.02.



EFFECTIVE: 12/10/09

**STANDARD COMBINATION AIR VALVE MANHOLE
(FOR FORCE MAINS)**

DETAIL No.

07200.02
SHEET 1 OF 1