

FRONT VIEW

NOTE: HEADWALLS WITH WINGWALLS REQUIRED ON BOTH ENDS

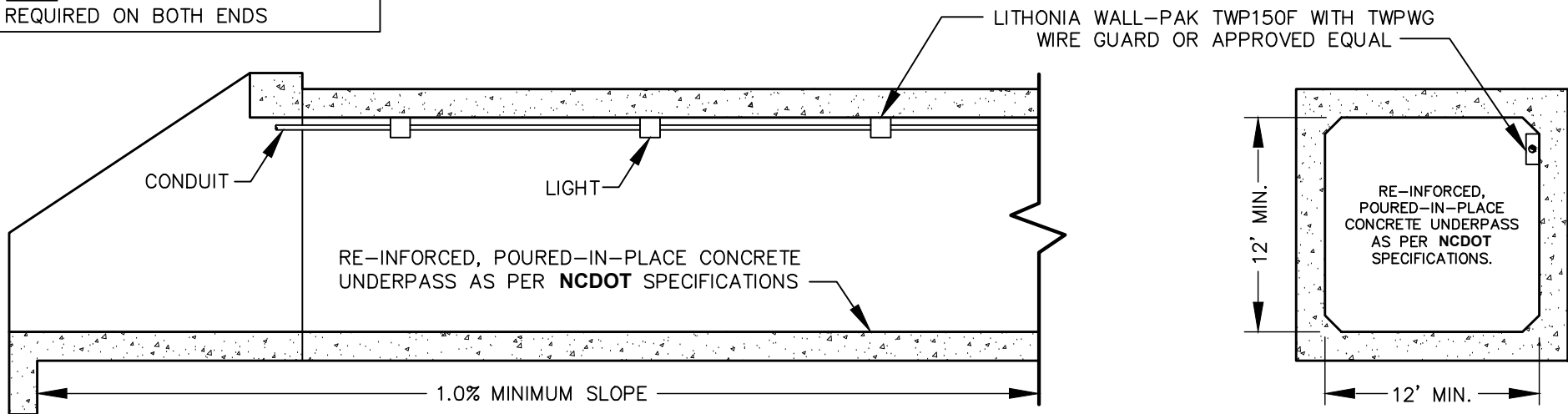

NOTES:

- 1) SEALING OF FIXTURES TO BE DESIGNED IN ACCORDANCE WITH **IES** STANDARDS.
- 2) APPROPRIATE SIGNAGE MAY BE REQUIRED AT ENTRANCE TO INDICATE NARROWING TRAIL WIDTH AND LIMITED VERTICAL CLEARANCE.

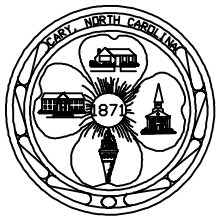

EFFECTIVE: 12/10/09

PEDESTRIAN/BICYCLE UNDERPASS

DETAIL No.

03000.17
SHEET 1 OF 1